



LUCCA TOWER BASIN MIXER

FEATURES:

- Extended body height (275mm) for use with counter top basins
- Vessel style body with upswept squareline handle and fixed spout
- 35mm ceramic disc cartridge
- Dual installation method enhancing all types of vanity
- Solid brass construction
- PEX core mixer hoses

WARRANTY:

*10 years limited warranty

**Please visit www.acplumbingsupplies.com.au for warranty details*

AVAILABLE IN



Chrome
192001



Matte Black
192001B

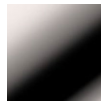

Brushed Nickel
192001N

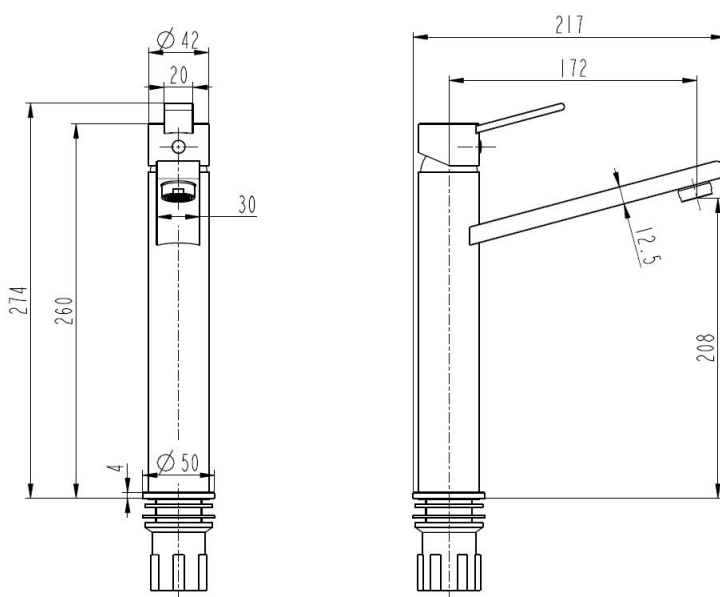

SPECIFICATIONS

Recommended Operating Pressure:
150 - 650kPa

Maximum Pressure Rating
1000kPa

Maximum Working Temperature
80°C

