



EMMA WALL MIXER WITH DIVERTER

PRODUCT CODE:

190404

FEATURES:

- Brass construction with easy clean chrome plated finish
- 35mm ceramic disc cartridge

WARRANTY:

*10 years limited warranty

Specifications

Recommended operating pressure: 150 - 650kPa

Maximum pressure rating: 1000kPa

Maximum working temperature: 80°C

**Please visit www.acplumbingsupplies.com.au for warranty details*

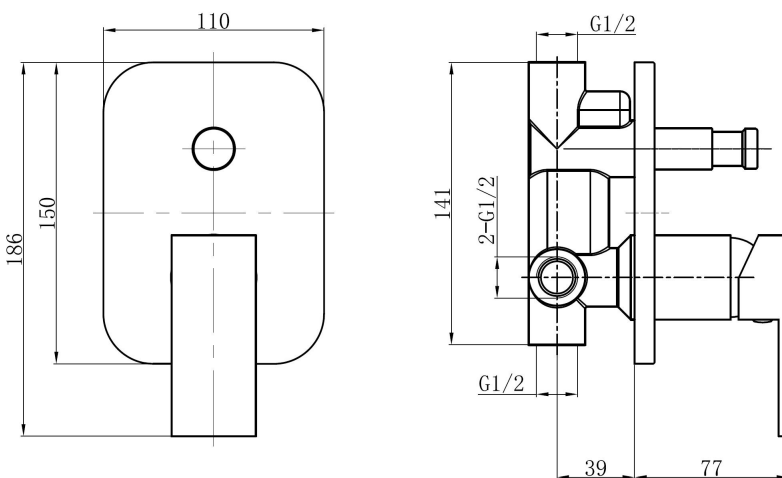

AUSTRALIAN CONSOLIDATED PLUMBING

T: 1300 020 269 F: 02 8105 9839 E: Info@acplumbingsupplies.com.au

23 Seton Rd, Moorebank, NSW 2170 www.acplumbingsupplies.com.au

Relino Tapware is registered trade mark of Australian Consolidated Plumbing.